

REVISION HISTORY			
REV.	DESCRIPTION	DATE	REVISED BY:

MRH-114-XXX

SINGLE STAGE HOLLOW OUTPUT RIGHT ANGLE GEARBOX

0.750" BORE

(XXX = GEARBOX RATIO)

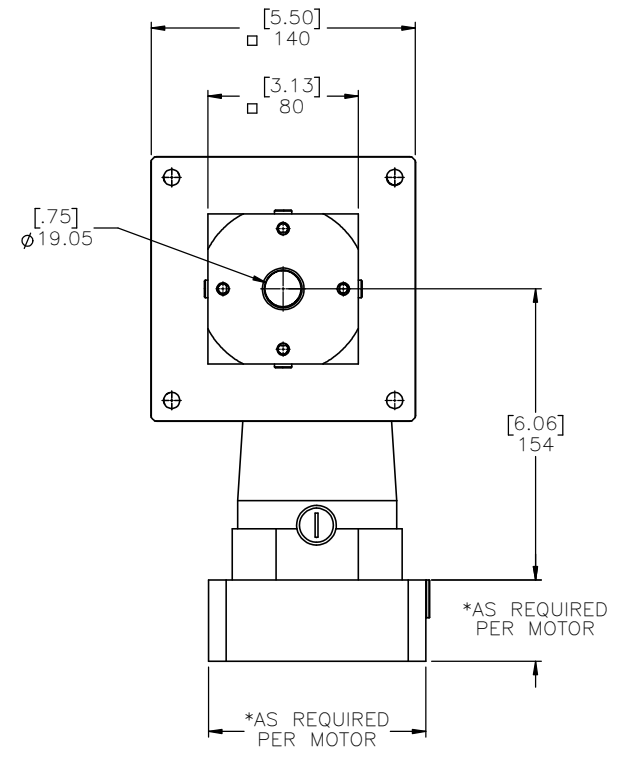
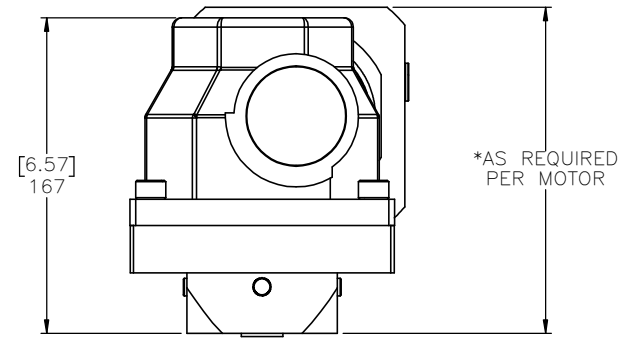
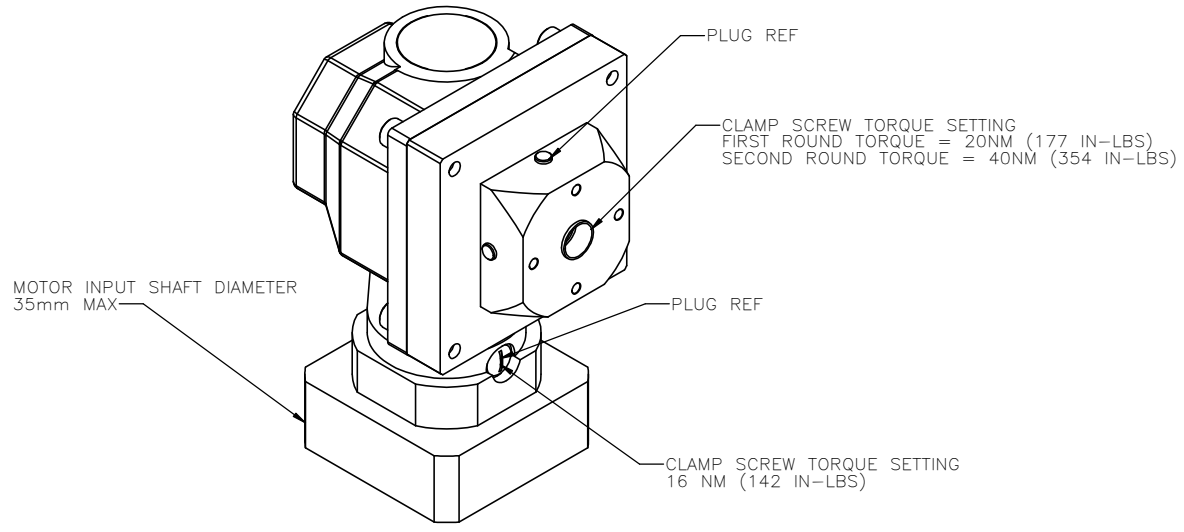

NOTES:

- 1.) MOTOR **MANUFACTURER AND MODEL NUMBER** REQUIRED TO PROPERLY SIZE THE MOTOR ADAPTOR PLATE. MAXIMUM MOTOR INPUT SHAFT DIAMETER IS 35mm.
- 2.) ADAPTOR PLATE SIZE WILL VARY BASED ON MOTOR SPECIFIED. OVERALL DIMENSIONS AND PLATE THICKNESS WILL BE DIFFERENT FROM VISUAL REPRESENTATION ABOVE
- 3.) MOTOR FLANGE BOLT CIRCLE PATTERN AND HOLE DIAMETER ALONG WITH MOTOR SHAFT DIAMETER AND LENGTH WILL DETERMINE THE FINAL SIZE OF THE ADAPTOR PLATE
- 4.) MACRON DYNAMICS, INC. MAKES EVERY EFFORT TO MATCH MOTOR DIMENSIONS TO MOTOR MANUFACTURER'S SPECIFICATIONS. THESE MANUFACTURER'S SPECIFICATIONS CAN CHANGE FROM TIME TO TIME WITHOUT NOTICE. MACRON IS NOT RESPONSIBLE FOR ADAPTOR THAT DO NOT MATE WITH THE MOTORS IF REFERENCE DIMENSIONS HAVE CHANGED OR IF THE USER CHANGES MOTOR MODELS AFTER PURCHASE
- 5.) TIGHTENING THE INPUT AND OUTPUT SCREW CLAMPS TO RECOMMENDED TORQUE IS CRITICAL TO SYSTEM FUNCTION. SHOULD OUTPUT CLAMP SLIP AFTER PROPER TIGHTENING, IT IS POSSIBLE THE MOTOR TORQUE IS EXCEEDING THE GEARBOX SPECIFICATIONS.

GEARBOX RATIO	5:1	10:1
MPG PART NUMBER SUFFIX	005	010
NOMINAL OUTPUT TORQUE - Nm (lb-in)	140 (1239)	140 (1239)
MAXIMUM ACCELERATION TORQUE - Nm (lb-in)	210 (1859)	210 (1859)
NOMINAL INPUT SPEED - RPM	2700	3000
MAXIMUM INPUT SPEED - RPM	5000	5000
STANDARD OUTPUT BACKLASH - arcmin	<6	<6
WEIGHT - kg (lb)	9 (19.8)	9 (19.8)
MASS MOMENT OF INERTIA - kg/cm2	3.6	2.9
EFFICIENCY AT LOAD	96%	96%

	DRAWN BY: TH DATE: 9/18/2018 CHECKED BY: -- DATE: DD/MM/YYYY LAST SAVED BY: Tim DATE: 12/30/2024	MATERIAL:	TITLE:
	UNLESS OTHERWISE SPECIFIED: DIMENSIONS ARE IN MILLIMETERS: .XX ± .254 TOLERANCES UNLESS NOTED: .XXX ± .127 OTHERWISE: ANG ± 0°30'	FINISH:	MACRON RIGHT ANGLE GEARBOX
	SURFACE FINISH: <input checked="" type="checkbox"/> BREAK ALL SHARP EDGES DIMENSIONAL LIMITS APPLY AFTER FINISHING THIRD ANGLE PROJECTION	SHEET: 1 OF 1 PART NUMBER: MRH-114-XXX	SCALE: 1:1 SHEET SIZE: C