

# MSA-R5D-B-AB- -

PULLEY PITCH DIAMETER	33.42mm (1.316")
PULLEY WIDTH	16.3mm (.642")
PULLEY MATERIAL	STEEL
BELT WEIGHT (kg)	$((\text{TRAVEL IN METERS} \times 2) + .50) \times .04$
TRAVEL PER REV.	105mm
TRAVEL MIN.	150mm
TRAVEL MAX.	3850mm
CART WEIGHT (kg)	0.74kg
SYSTEM WEIGHT (kg)	$(\text{TRAVEL IN METERS} \times 4.6) + 2.1$

**ENTER**  
TRAVEL IN INCREMENTS OF 25mm

**SELECT**  
DRIVE SHAFT LOCATION\*

**SHAFTING TYPE**  
A0=SINGLE SHAFTED  
B0=DOUBLE SHAFTED

NOTE: (IF "B" IS USED THE NUMBER WILL DESIGNATE POSITION OF THE BOSS ON THE PULLEY)

AM=SINGLE SHAFTED W/ MOTOR MOUNT  
BM=DOUBLE SHAFTED W/ MOTOR MOUNT

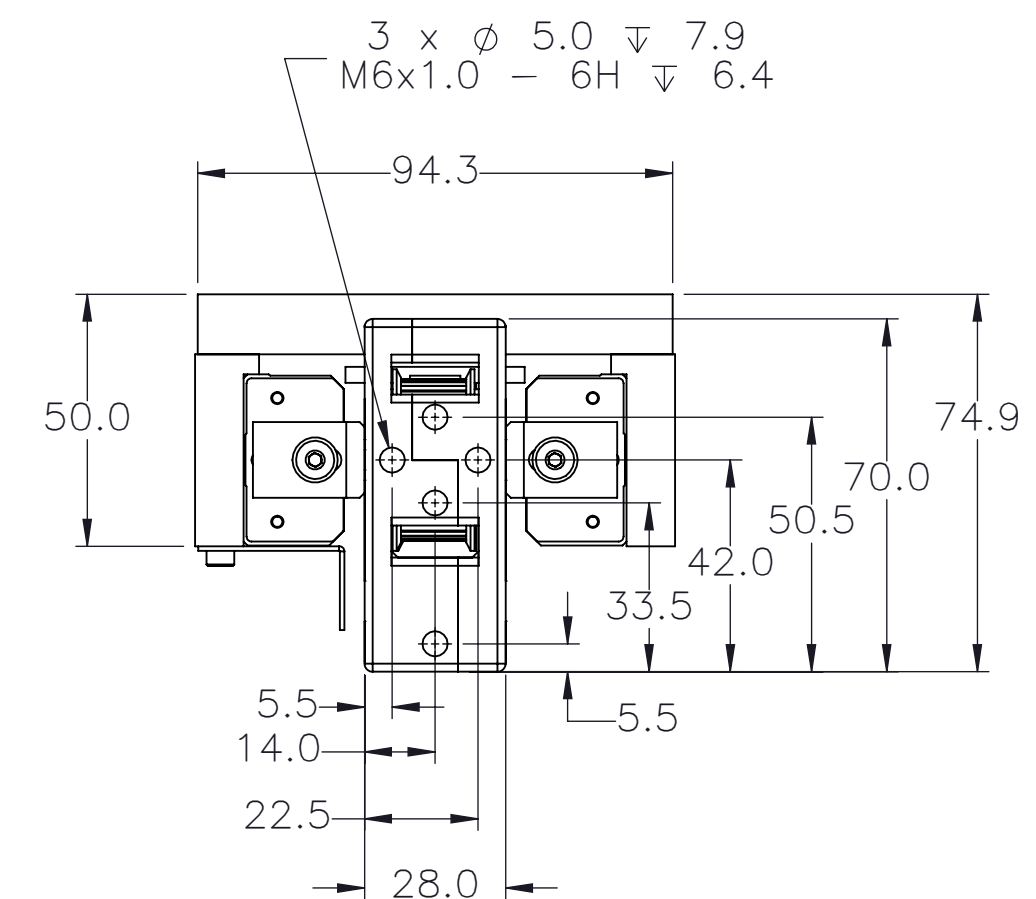
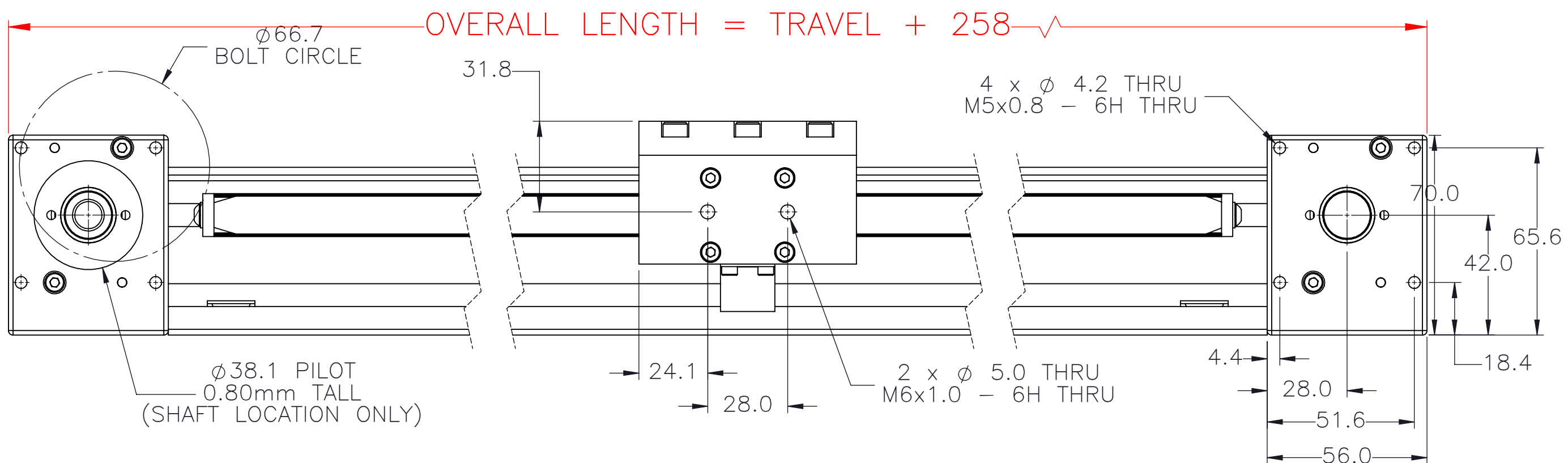
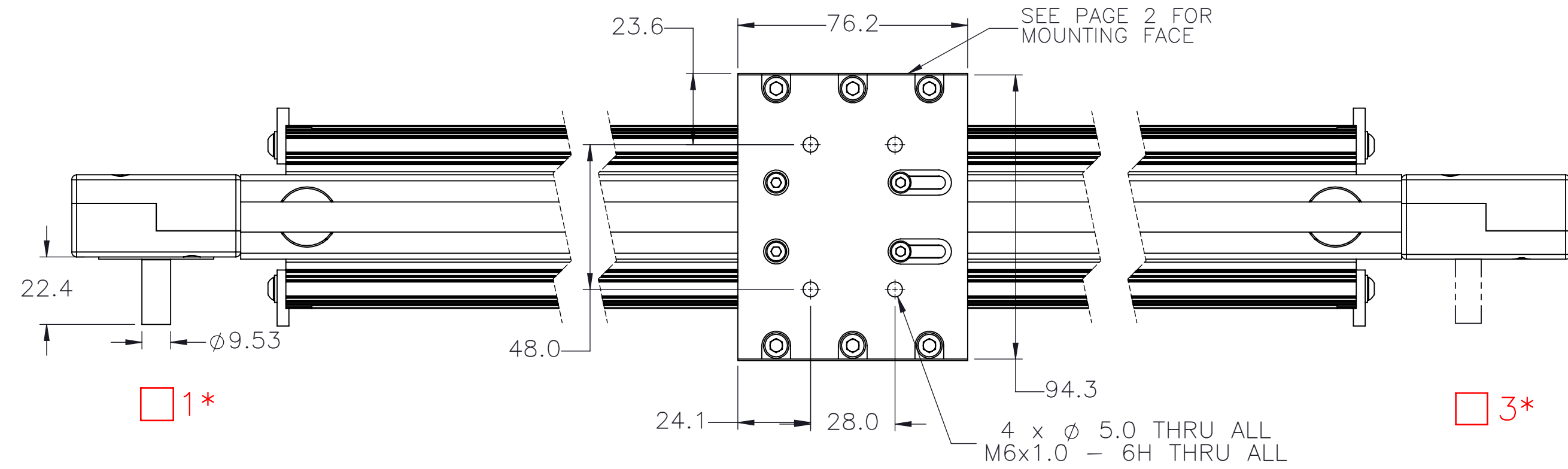
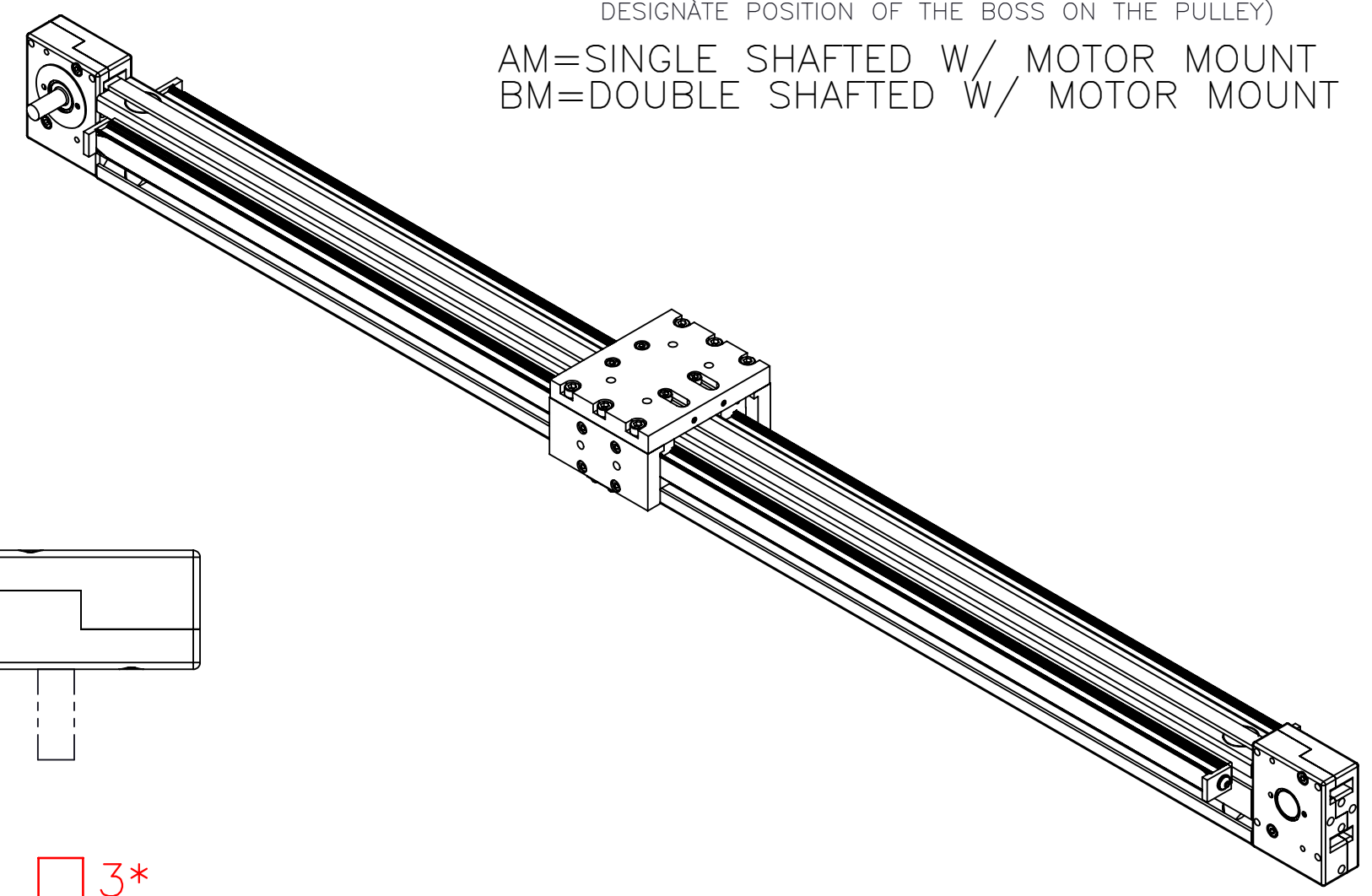

APPROVED: \_\_\_\_\_

DATE: \_\_\_\_\_

<p>MACRON DYNAMICS INC</p>	DRAWN BY: PHW CHECKED BY: -- LAST SAVED BY: Tim	DATE: 11/26/2017 DATE: DD/MM/YYYY DATE: 5/30/2023	MATERIAL:  FINISH:	TITLE: MACRON R5D RAIL ACTUATOR
	UNLESS OTHERWISE SPECIFIED, DIMENSIONS ARE IN INCHES. TOLERANCES UNLESS NOTED OTHERWISE: .X ± .03 .XX ± .010 .XXX ± .005 ANG ± 0°30'			SCALE 1:1 SHEET SIZE C
	SURFACE FINISH $\checkmark$ BREAK ALL SHARP EDGES DIMENSIONAL LIMITS APPLY AFTER FINISHING THIRD ANGLE PROJECTION			SHEET 1 OF 2 PART NUMBER
	THIS DRAWING IS THE PROPERTY OF MACRON DYNAMICS. ANY REPRODUCTIONS SHALL BE FOR QUOTATION, MANUFACTURING, OR PURCHASING PURPOSES ONLY. RELEASE OF DRAWINGS TO OTHER CONCERNS DOES NOT CONSTITUTE LICENSING IN ANY WAY. INFORMATION CONTAINED HEREIN IS PROPRIETARY AND CONFIDENTIAL.			SCALE 1:1 SHEET SIZE C REV MSA-R5D

SPECIFICATIONS ARE SUBJECT TO CHANGE WITHOUT NOTICE

### CART MOUNTING FEATURES

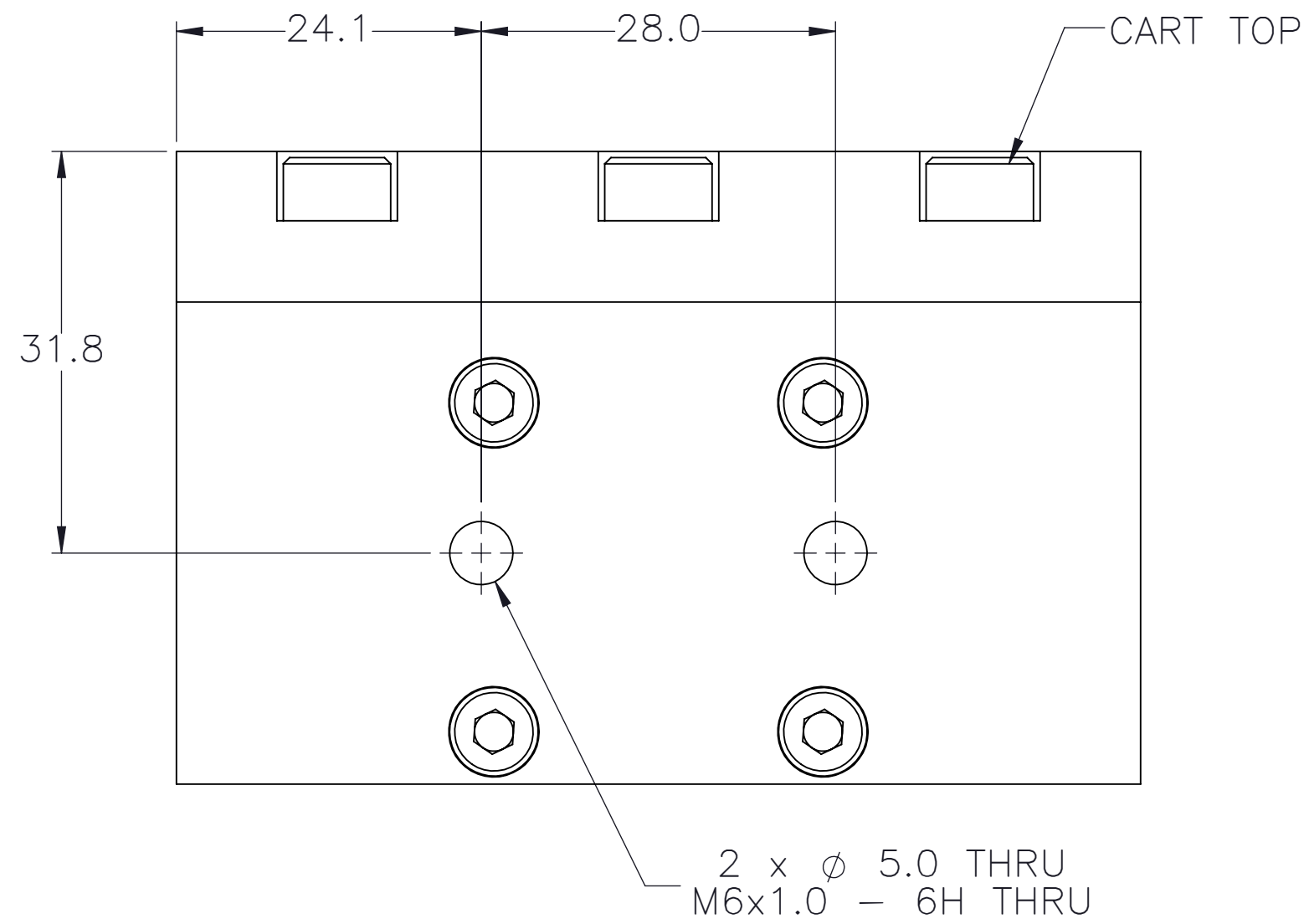

### DOUBLE SHAFTED PULLEY

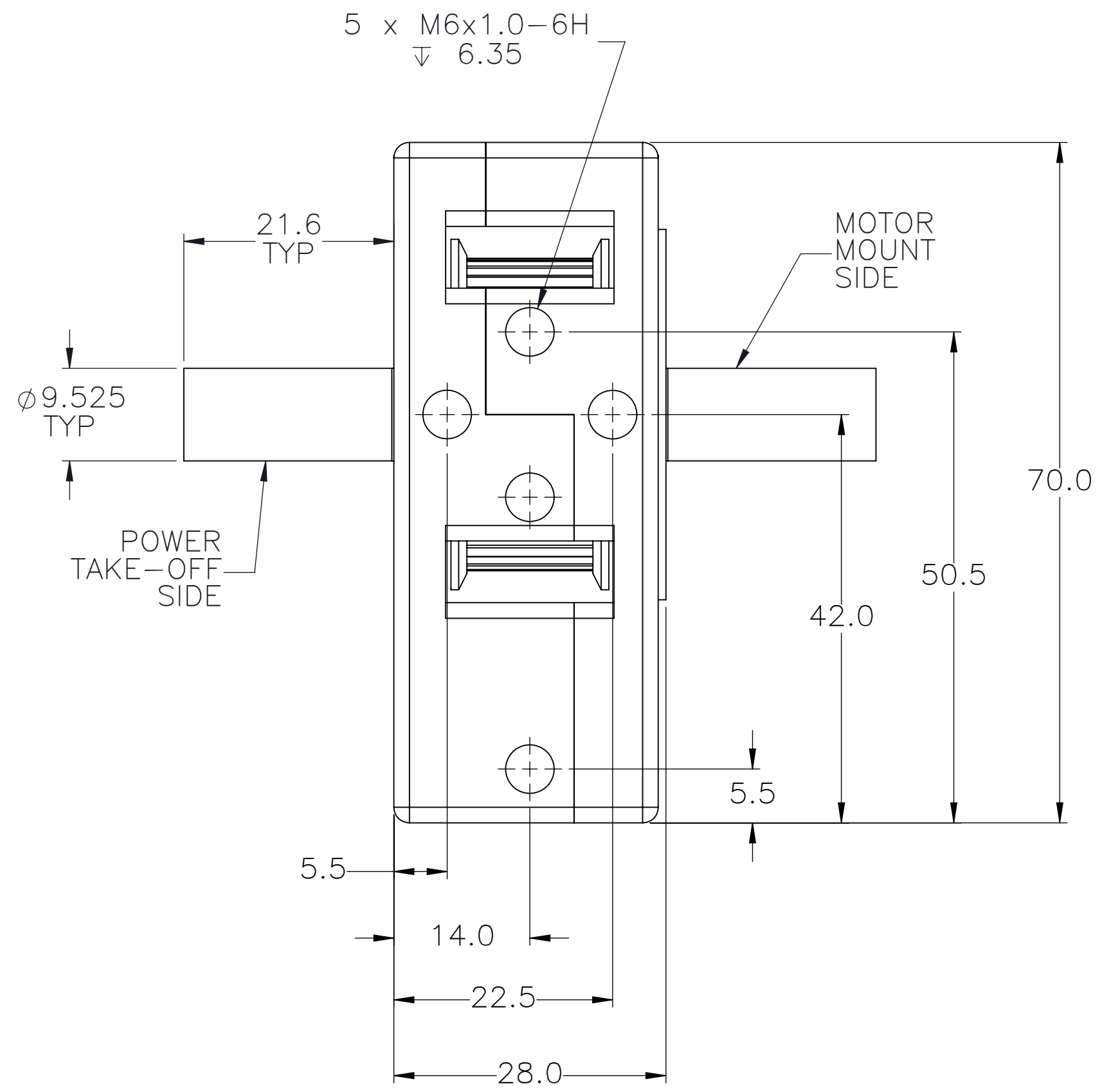
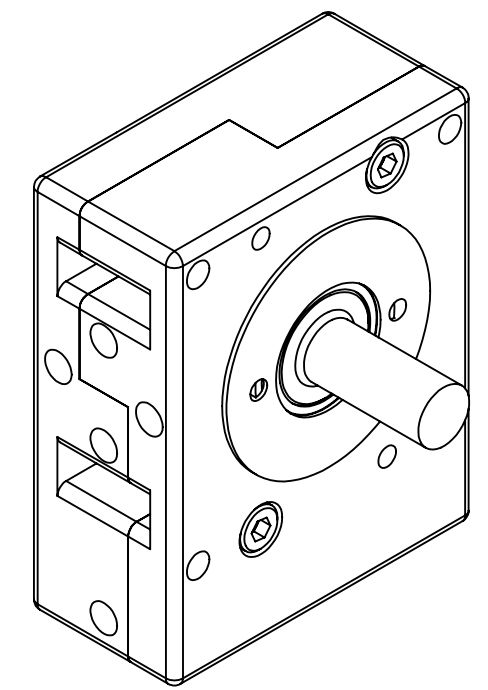

### CUSTOMER ACCESSIBLE MOUNTING FEATURES, T-NUT SLOTS

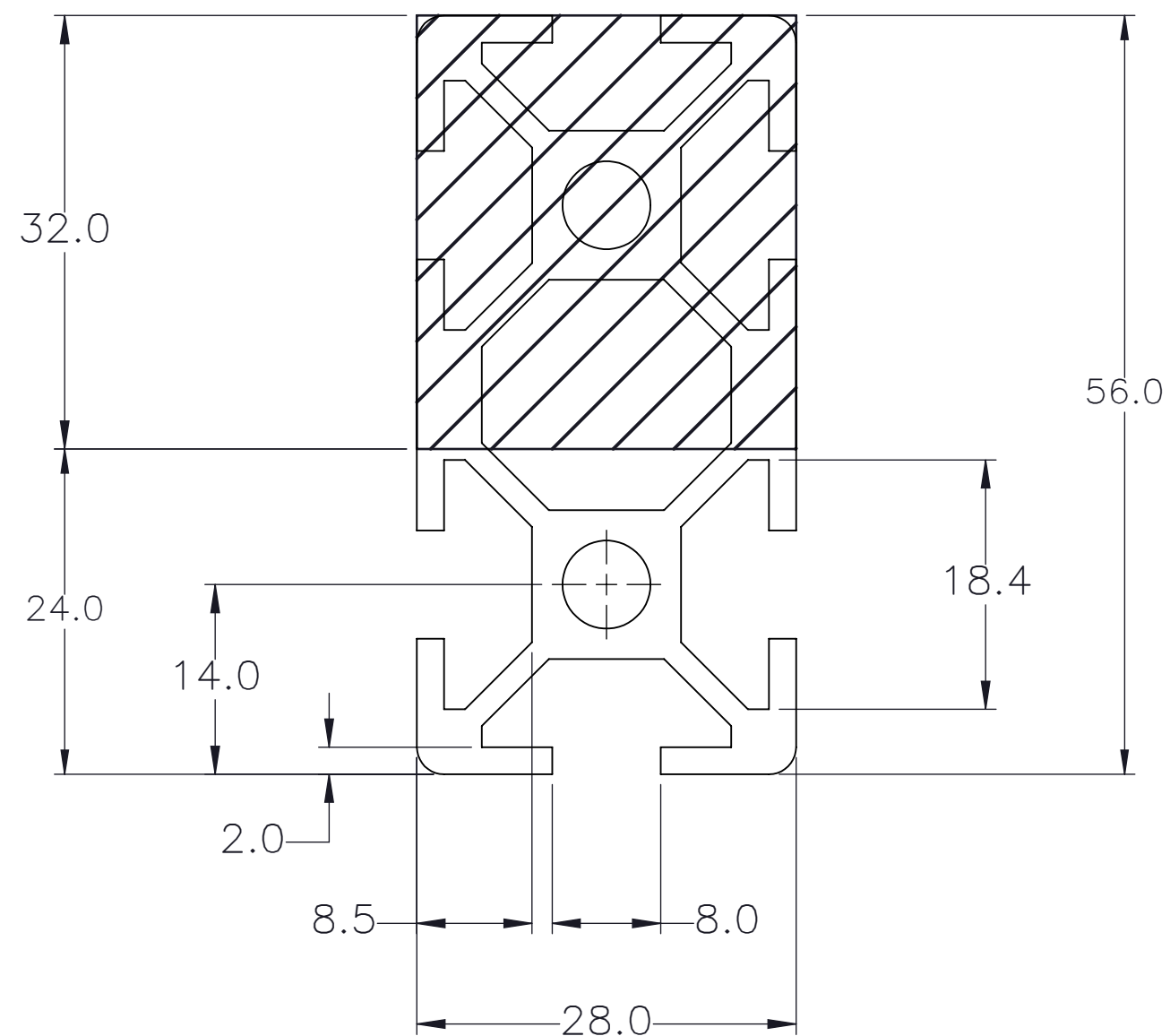

SPECIFICATIONS ARE SUBJECT TO CHANGE WITHOUT NOTICE

**MACRON DYNAMICS INC**

THIS DRAWING IS THE PROPERTY OF MACRON DYNAMICS. ANY REPRODUCTIONS SHALL BE FOR QUOTATION, MANUFACTURING, OR PURCHASING PURPOSES ONLY. RELEASE OF DRAWINGS TO OTHER CONCERNS DOES NOT CONSTITUTE LICENSING IN ANY WAY. INFORMATION CONTAINED HEREIN IS PROPRIETARY AND CONFIDENTIAL.

DRAWN BY: PHW	DATE: 11/26/2017
CHECKED BY: --	DATE: DD/MM/YYYY
LAST SAVED BY: Tim	DATE: 5/30/2023

UNLESS OTHERWISE SPECIFIED, DIMENSIONS ARE IN INCHES. TOLERANCES UNLESS NOTED OTHERWISE:

.X ± .03
.XX ± .010
.XXX ± .005
ANG ± 0°30'

SURFACE FINISH  $\checkmark$   
 BREAK ALL SHARP EDGES  
 DIMENSIONAL LIMITS APPLY AFTER FINISHING  
 THIRD ANGLE PROJECTION

MATERIAL:	TITLE:
FINISH:	MACRON R5D RAIL ACTUATOR
SHEET	PART NUMBER
2 OF 2	MSA-R5D

SCALE 1:1	SHEET SIZE C
REV	